

# TOTAL GYM POWERTOWER™ ASSEMBLY AND SET-UP INSTRUCTIONS

## TOTAL GYM POWERTOWER BOX CONTENTS:

- Tower, Rail and Glideboard Assembly
- Telescoping Squat Stand
- Tower Feet Box
- LAT Bars and Arm Pulley Cable Assembly
- Folding Foot Holder
- Hardware & Information Box
- Folding Platform

## TOTAL GYM POWERTOWER™ HARDWARE & INFORMATION BOX CONTENTS:

- Spanner Wrenches (2)
- Quick Links (2)
- Safety Key (1)
- Assembly Instructions and Owner's Guide
- Plastic Axle Caps (2)
- Strap Handles (2)
- Power Cord (1)
- Assembly, Set-up and Storage DVD
- Round Nuts (2)
- Remote Control Handles (2)

TotalGym.com

U.S. Customer Service: 858.586.6080

## REMOVING TOTAL GYM POWERTOWER FROM THE BOX

- 1** Remove the lid of the Total Gym® box and set it aside.

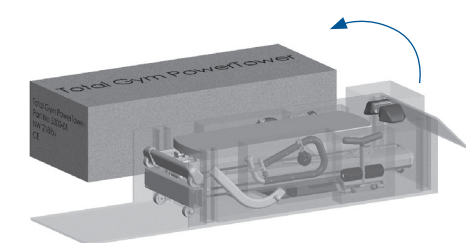

- 2** Remove all interior boxes from the top and sides. Cut the tape on the end of the box at the base of the tower. Unfold that end of the box. Slide the PowerTower® out of the box about one foot.

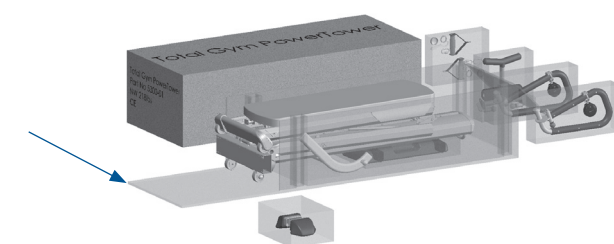

- 3** Open the Tower Feet Box. Install the feet on the tower.

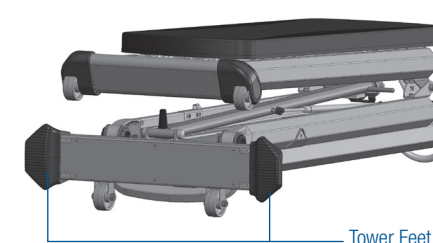

- 4** Stand the Total Gym PowerTower™ upright and roll it to the location where you want the tower to stand.

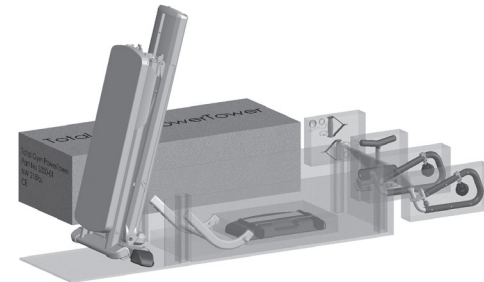

- 5** Remove the folding platform and the telescoping squat stand parts from the bottom of the box.

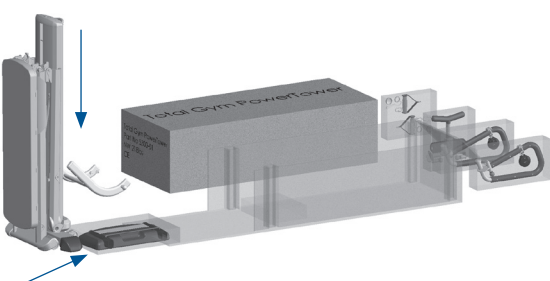

## UNFOLDING TOTAL GYM

- 6** Unlatch the rails from the tower.

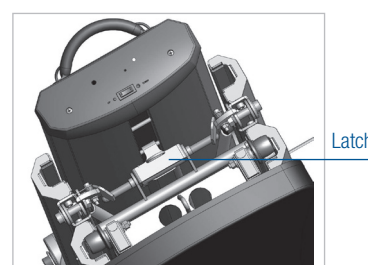

- 7** Standing at the side of the unit, with one hand behind the tower and the other hand on the glideboard, tilt the unit slightly backward and use your foot to push the rail base away from the tower. The tower will follow the upper rails forward and then it will begin to pull away from the rails, backward to an upright position.

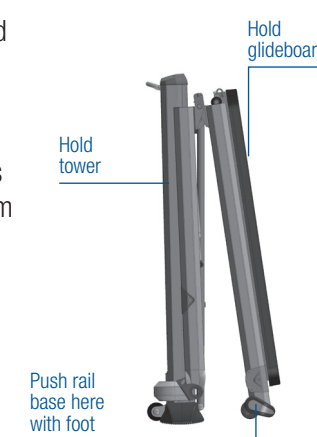

**Caution!** The tower is designed to open automatically by pulling away from the upper rails as the rails begin to unfold. Do not force or push the tower away from the rails, as this may cause the tower to fall backward.

- 8** When the tower begins to pull away from the upper rails, grasp the upper rail where indicated on the inside of the rail just above the hinge (indicated on both sides) and continue to unfold the rails and lower them to the floor. As the rails straighten, guide the glideboard rollers into the groove of the upper rail if needed.

**Caution!** As the rails get close to the floor, the rails feel heavier. To avoid pinching the rollers in the hinges, do not drop the rails.

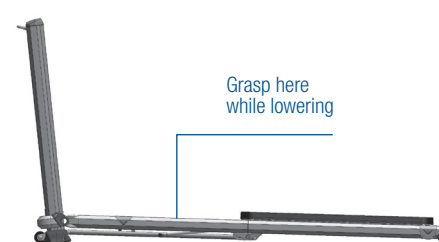
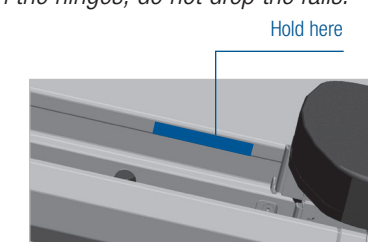

## ADJUSTING THE INCLINE OF THE RAILS

### CONNECTING POWERTOWER® TO A POWER SOURCE

- 9** Plug the power cord into the back of the PowerTower and into a wall socket.
- 10** Insert the safety key into the connector hole located on top of the tower.
- 11** Turn the On/Off power switch on. The red light indicator should be glowing.

### RAISING AND LOWERING THE INCLINE OF THE RAILS:

- 12** Stand next to the top rails.
- 13** Press the rocker switch on the top of the tower to raise or lower the rails to the desired level. The incline scale is located on the side of the tower.

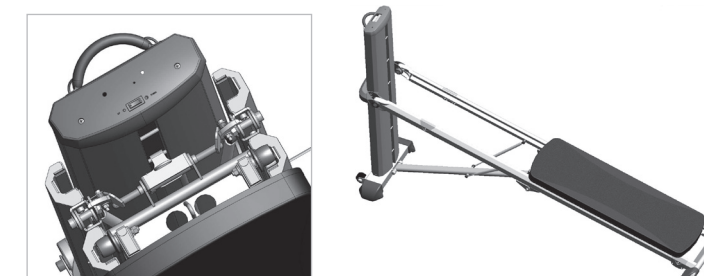

- 14** To continue assembly, raise the rails to between level 10 and 14.

## LAT BAR ASSEMBLY

After you remove your Total Gym PowerTower™ from the box and unfold it, it is ready for you to install the LAT bars. It should look like the picture below. Notice the shipping sleeve shown and the round nuts must be removed one side at a time to install the LAT bars.

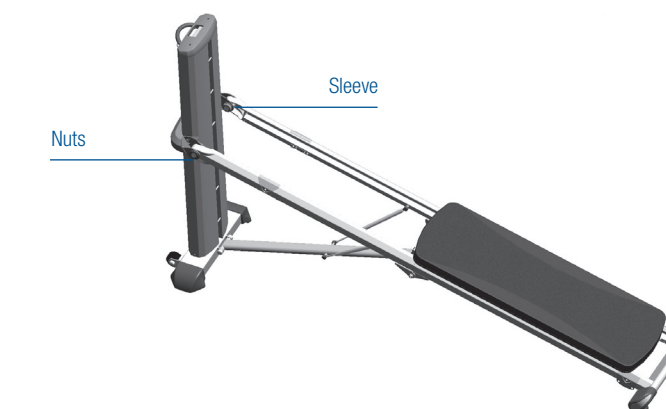

- 15** Open the hardware box and remove the spanner wrenches.

The picture below shows tools and parts needed to install the LAT bars, found in the hardware box: You need 2 round nuts, 2 spanner wrenches and 2 plastic axle caps.

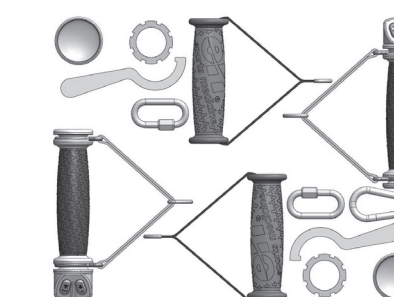

- 16** Install one LAT bar completely, then install the other to keep the PowerTower® stable and safe.

- 17** Using both spanner wrenches, hold the inner round nut stationary with one wrench (on the inside of the rail) and turn the round nut on the outside of the rail to loosen and remove the shipping sleeve (shown below).

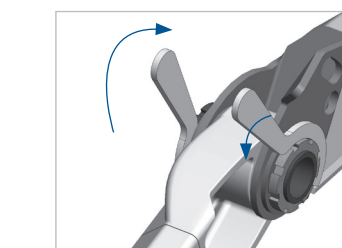

- 18** Carefully slide the shipping sleeve out while holding the bushing in. If the bushing slides out accidentally, slide it back through the hole in the tower cross arm and into the rail.

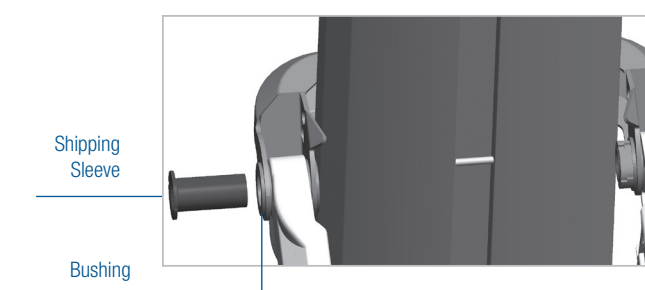

total gym

total gym

**19** LAT bars are specific to each side of the tower. When installed the pulley pin locators will be facing backward away from the front of the unit.

**20** While holding the inside rail bushing so it does not slide out, insert the correct LAT bar through the bushings until it is flush with the outside rail bushing.

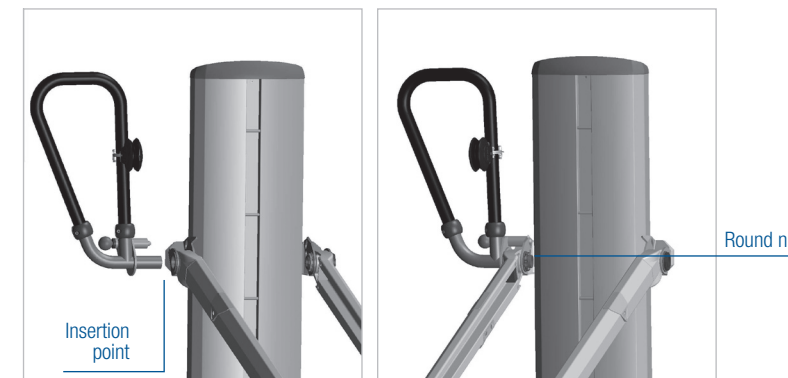

**21** Reinstall a round nut and tighten it so the LAT bar rotates freely but with slight friction.

**22** Install the second round nut on the same LAT bar until it is tight against the first nut. Hold one spanner wrench on the inner round nut so it will not move. Then use the other spanner wrench to tighten the second round nut against the first. See image below.

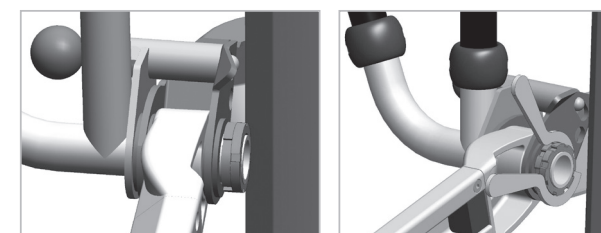

**23** Rotate the LAT bar to feel if it moves easily but with slight friction.

**24** If necessary, adjust the tightness by adjusting the round nut closest to the rail and retighten the second nut as explained in Step 22.

**25** Repeat the process on the other LAT bar.

**26** When you are finished adjusting the tightness of the LAT bars, install both axle covers over the round nuts as shown below:

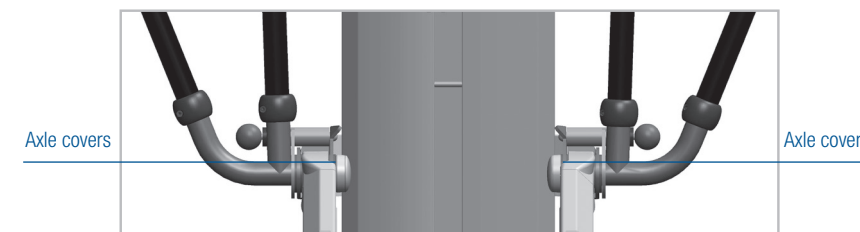

### ADJUSTING THE LAT BARS

**27 Pull-up Position:** Pull the retractable knobs to disengage the LAT bars from the tower cross arm and rotate the LAT bars down until they rest on the rail.

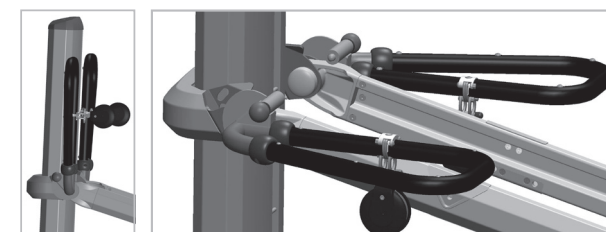

**28 Cable and Pulley Use Position:** Raise the LAT bars to use the pulleys and cable. Rotate each LAT bar up and parallel with the tower, ensuring the pull pin engages in the hole of the tower cross arm on both sides.

**29 Changing the Pulley Pin Position:** Squeeze the pulley clamp and move it to the desired position along the LAT bar. Be sure the pulley clamp engages one of the pin positions on the back of the LAT bar.

### FOLDING FOOT HOLDER INSTALLATION

Your Total Gym PowerTower™ arrives with the folding foot holder, which needs to be installed. Remove the folding foot holder from the box and install it on the upper rails.

**30** Place the rails at or above level 10 so you have room to install the folding foot holder from underneath the rails. Aim one pin into the hole of a rail while holding the folding foot holder upper bar even with the middle of the rails.

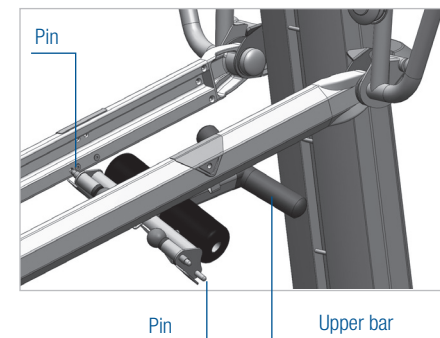

**31** Continue to hold the folding foot holder upper bar even with the middle of the rails. Pull the pin on the other side. Align and insert it into the hole in the opposite rail, and release the pin. Ensure both pins are fully engaged in the rails.



**32 Folding Foot Holder Use Position:** Pull up on the upper bar to engage the folding foot holder for use. Depress the lever where indicated to fold down when not in use.



### TELESCOPING SQUAT STAND ASSEMBLY

There are two attachments that make up the telescoping squat stand assembly—the folding platform attachment and the squat stand attachment.

#### FOLDING PLATFORM ATTACHMENT

**33** Stand at the base of the rails facing the tower. Hold the folding platform with a hand on each post. Partially angle the posts toward the glideboard. Align the upper fixed pin on the left with the top hole on the lower rail. Allow the lower pull-pin to press against the plate on the left side of the rail as you guide the upper fixed pin into the hole.

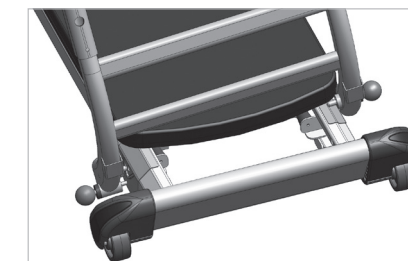

**34** When the fixed pin is inserted into the hole gently move the folding platform to the right. Then lower the right side of the folding platform down to align the right pull-pin into the plate on the right lower rail as shown below. You may need to pull the right pull-pin.

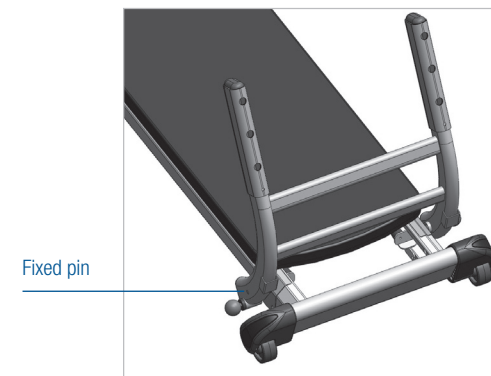

**35** When both left and right pull-pins are engaged into the rails, rotate the folding platform away from the glideboard until the lower pull-pin on the left side pops into the rail hole. To fold the platform for storage, simply disengage the lower left pull-pin and fold the platform (the squat stand will be attached).

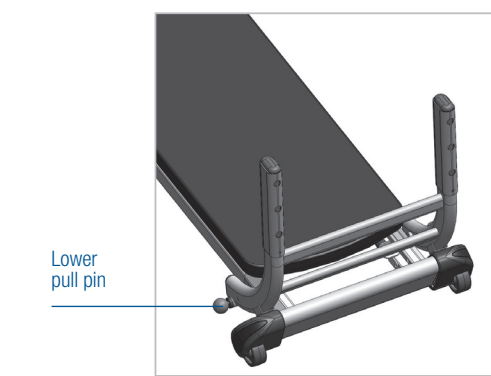

### TELESCOPING SQUAT STAND ATTACHMENT

**36** Lift the release lever on the back of the telescoping squat stand. Align the squat stand receptacle posts over the folding platform posts. Slide the squat stand down and align it with one of the three levels indicated by the holes in the posts. Release the lever to lock the squat stand into place.



**37** Inspect the lever and pull up on the squat stand handle to insure the squat stand is locked in on both sides.

### INSTALLING THE HANDLES

**38** Open the hardware box and remove the handles and threaded quick links as shown. Install them on each end of the cable.

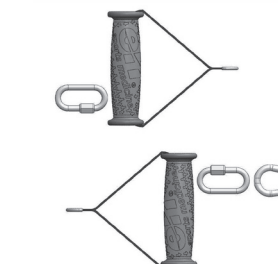

### ALMOST FINISHED

**39** When the assembly is finished, look for extra parts to ensure no steps were missed. Inspect your Total Gym® for defects and contact Customer Service if you feel you have any problems. Before using your new Total Gym, read the safety and usage instructions in the Owners Guide.

**YOUR TOTAL GYM POWERTOWER™ IS NOW READY TO USE.**